

Model: CC3WXXX Triac  
CC6WXXX Triac



Model	Output Current	Input Current	Input Power	Output Power Range	PF	Efficiency	Output Voltage	No load Voltage
CC3W120 Triac	120mA	0.06A	7W	2.28-3.6W	0.9	60%	19-30V	45V
CC3W180 Triac	180mA	0.06A	7W	2.34-3.78W	0.9	60%	13-21V	35V
CC3W200 Triac	200mA	0.06A	7W	2.6-4.2W	0.9	60%	13-21V	35V
CC3W260 Triac	260mA	0.06A	7W	2.08-3.38W	0.9	60%	8-13V	25V
CC3W300 Triac	300mA	0.06A	7W	2.4-3.9W	0.9	60%	8-13V	25V
CC3W350 Triac	350mA	0.06A	7W	2.8-4.55W	0.9	60%	8-13V	25V
CC6W120 Triac	120mA	0.08A	10W	4.32-6W	0.9	70%	36-50V	65V
CC6W180 Triac	180mA	0.08A	10W	4.86-7.02W	0.9	70%	27-39V	55V
CC6W200 Triac	200mA	0.08A	10W	3.8-6W	0.9	70%	19-30V	45V
CC6W250 Triac	250mA	0.08A	10W	3.25-5.25W	0.9	70%	13-21V	35V
CC6W300 Triac	300mA	0.08A	10W	3.9-6W	0.9	70%	13-20V	35V
CC6W350 Triac	350mA	0.08A	10W	4.55-6.65W	0.9	70%	13-19V	35V
CC6W400 Triac	400mA	0.08A	10W	3.2-5.2W	0.9	70%	8-13V	25V
CC6W450 Triac	450mA	0.08A	10W	3.6-5.85W	0.9	70%	8-13V	25V
CC6W500 Triac	500mA	0.08A	10W	4-6W	0.9	70%	8-12V	25V

\* Test result @230V, 50Hz, Full Load.

### 1. Parameters

category	Item	Technical Norm
Features	Output Type	Constant Current
	Dimming Type	Phase dimming
	Dimming Range	5%-100%
	IP Grade	IP44
	Insulation Class	Class II
Input	Rated Input Voltage	220-240VAC
	Range of Input Voltage	198-264VAC
	Frequency	50/60Hz
	Input Current	≤0.08A (198VAC, full load)
	Input Power	≤ 9.5W (230VAC, full load)
	Power Factor	≥0.9 (230VAC, full load)

	No-load Power Consumption	≤0.5W @230VAC
	Inrush Current	≤8A/400us (230VAC, Full-load)
	Connected quantity of 16A Breaker	40pcs/type B ; 64pcs/type C @ 230Vac
Output	Current Accuracy	±5%
	Max. Output Power	7.02W
	Started Delay Time	≤0.5S (230VAC, full load)
	Current Ripple	±5% ((Imax-Imin) / (Imax+Imin))
Protection	Short Circuit Protection	Auto Recovery
	Overload Protection	Auto Recovery
	No-load Protection	Auto Recovery
	Insulation voltage	I/P to O/P , 3.75KVac/1min
	Insulation resistance	>100M ohm @ 500VDC
	Leakage current	I/P to O/P < 250 μ A
Environment	Ta/Operation Temperature	-20....+50 °C
	Ts/Storage Temperature	-25....+85 °C
	Tc/Enclosure Temperature	85 °C
	Humidity	10%....90%RH
	Atmosphere	86-108KPa
Construction	Connection Method	Direct Lead
	Installation	Build-in
	PRI Wire preparation	0.5-1.5□
	SEC Wire preparation	0.5-1.5□
	Dimension	48.2*30*20mm (L*W*H)
Standards	Certification	TUV、CE、SAA
	Safety Standards	EN61347-1:2015,EN61347-2-13:2014/A1:2017 ,EN62493:2015, AS/NZS IEC61347.2.13:2013, AS/NZS 61347.1:2016
	EMC Standards	EN55015:2013/A1:2015,EN61000-3-2:2014,E N61000-3-3:2013,EN61547:2009
	Performance	EN62384
	Surge	L-N/ 1KV
Others	RoHS	complied to 2011/65/EU
	Life Time	50000h @50°C (Ta) / @85°C (Tc)
	Warranty	5years , F.R. < 10000ppm

Remark: 1.All Parameters, if not specified, are measured at 230VAC/50Hz and 25°C ambient temperature.  
2.LED Driver is a component of the luminaires. Luminaires and wire layout will affect the EMC, please check the EMC with end products again.

### 2. Trailing Edge Dimmer list approved by KGP

Manufacturer	Model	Q'ty of parallel connection
ABB	6519 U	15
ABB	6526 U	13
JUNG	1224 LED UDE	14
Berker	2861	10
JUNG	254 UDIE 1	10
JUNG	225 TDE	14
EGANT	U321V2	15
Schneider	SBD200LED	13
Schneider	SBD315RC	14
Merten	SBD200LED	13
Berker	2874	12
Eetako	EUD61NPL-230V	12

*Leading Edge Dimmer list only on request -/ or confirmed by KGP Electronics*

### 3. Label (For example)

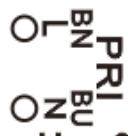
**KGP** LED Dimmable Driver  
KGP Electronics GmbH  
Hueckstraße 19  
DE-58511 Lüdenscheid **CC6W500 Triac**

$U_N = 220-240V_{ac}$   $U_{OUT} = 8-12V_{dc}$  ●  $t_c$

$I_N = 0.08A \text{ max.}$   $I_{OUT} = 500mA \text{ const.}$

$f_N = 50/60Hz$   $P_{OUT} = 6W \text{ max.}$

$PF \geq 0.9$    $U_{max} = 35V_{dc}$   $I_{SE}$   $I_{BK}$   $I_{RD}$   $I_{+}$

$t_c = 85^\circ C$   $t_a = 50^\circ C$  **SELV**



For LED modules only

### 4. Dimension (Unit: mm)

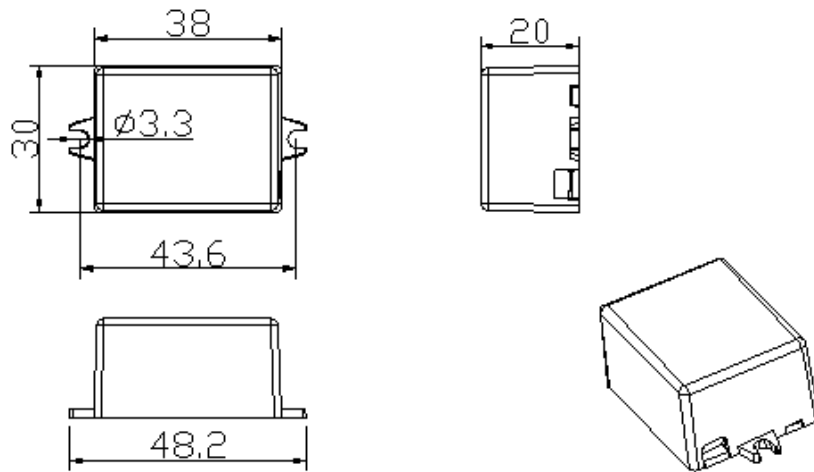

### 5. Packing information

Carton L*W*H(mm)	Pcs/Carton	Net weight/ Pcs(kg)	Net weight/ Carton(kg)	Gross weight / Carton(kg)
450*240*200	250	0.05	12.5	13.3

### 6. Wiring Diagram

